

WATER RIGHT®

QUALITY WATER SOLUTIONS

Installation Instructions & Owner's Manual

Water-Right Sanitizer Series™ ***Water Conditioners***



WATER  RIGHT®

QUALITY WATER SOLUTIONS

1900 Prospect Court • Appleton, WI 54914
Phone: 920-739-9401 • Fax: 920-739-9406



CAUTION: The manufacturer does not recommend the use of any resin cleaners. Please refer to page 6 in this manual or the warning label on the back of the brine tank.

TABLE OF CONTENTS:

Installation Instructions	Page 3-4
Start-up Procedures	Page 5-6
Programming the Sanitizer Timer	Page 6-9
Programmable Features of the Sanitizer Timer	Page 10
Light/Alarm Operation	Page 11
Water Conditioner Flow Diagrams	Page 12
Troubleshooting	Page 13-14
Parts & Assembly Diagrams	Page 15-18
Blank	Page 19
Capacity & Physical Specifications	Page 20

YOUR WATER TEST

Hardness _____gpg
Iron _____ppm
pH _____number
*Nitrates _____ppm
Manganese _____ppm
Sulphur _____yes/no
Total Dissolved Solids _____

*Over 10 ppm may be harmful for human consumption. Water conditioners do not remove nitrates or coliform bacteria, this requires specialized equipment.

Your Sanitizer Series water conditioners are precision built, high quality products. These units will deliver conditioned water for many years to come, when installed and operated properly. Please study this manual carefully and understand the cautions and notes before installing. This manual should be kept for future reference. If you have any questions regarding your water conditioner, contact your local dealer or Water-Right at the following:

Water-Right, Inc.
1900 Prospect Court • Appleton, WI 54914
Phone: 920-739-9401 • Fax: 920-739-9406

PRE-INSTALLATION INSTRUCTIONS:

Although the Sanitizer Series Water Conditioner is shipped complete, some assembly may be required.

1. After unboxing the unit, remove "split flange" from control valve adaptor base, remove cardboard tank shim. Inspect "O" Ring on top of flange and grease with silicone provided. Place valve (shipped in a separate box) on adaptor base. The valve is "keyed" and will only attach one way. Using split flange, attach control valve to tank.



CAUTION: The "split flange" should secure the valve with the top of the flange facing up. Please note "top" on the split flange.

2. Install the chlorine generator on the brine valve (*Fig. 3*) by pulling the brine clip, inserting the generator and resealing the clip. Plug generator's electrical end into receiving adaptor in the back plate. Do not install brine line at this time.



CAUTION: Never grab onto the generator to move unit. This will result in cracking the valve body.

3. Install meter and bypass, if ordered, (*Fig. 3*) using silicone grease provided on "O" Rings. Extra "O" Rings have also been provided in case a tear occurs during installation.

NOTE: Meter should be installed between the control valve and the bypass with the meter "turbine" being installed on the outlet side of the control valve (*Fig.3*).

4. Secure both the meter and the bypass using the clips provided.

NOTE: There will be some up and down "play" and should not be of concern since the "O" Rings will seal and no leaks should occur.

INSTALLATION INSTRUCTIONS:

IMPORTANT: In the following installation instructions various types of plumbing pipe are recommended. These types may or may not be approved for your local plumbing codes. All plumbing must be installed according to local plumbing codes.

1. A selection site should be chosen for your conditioner. If you have a well system, this would be after the pressure tank but before the hot water heater (*Fig. 1*). If you have city water, install the softener on the inlet line to the building before the hot water heater (*Fig. 2*).

NOTE: Try to locate the softener as close to a drain (floor drain, sump pump, etc.) as possible.

WELL WATER INSTALLATION

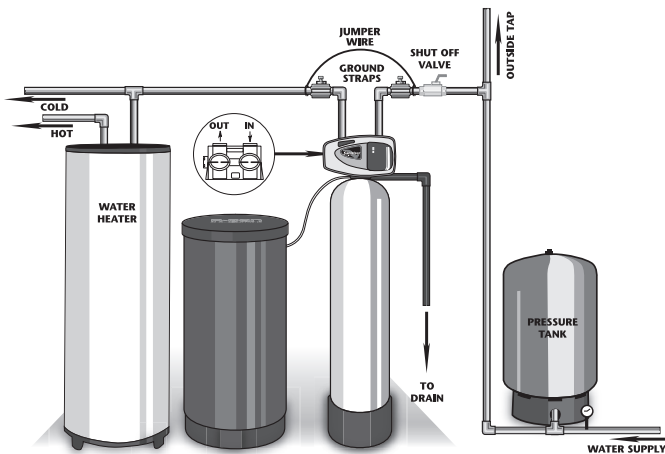

Figure 1

MUNICIPAL INSTALLATION

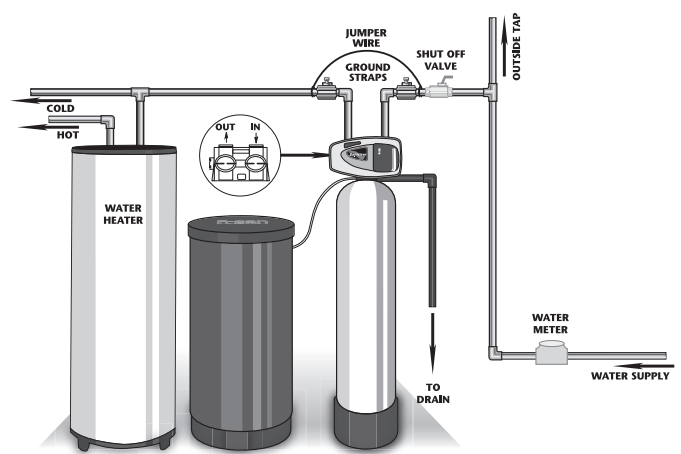

Figure 2

- Notice on the casting, the inlet and outlet markings, make sure the incoming water is plumbed to the inlet and outlet is plumbed to service (*Fig. 3*). Your water softener must be installed with a bypass valve. If your conditioner is not equipped with one, make a provision in the plumbing system for a bypass to be installed.

IMPORTANT: Make sure the water is turned off and pressure is released before a cut is made into plumbing system. At this time you should also make provisions for hard water lines to outside tap and anywhere else desired.

- To “bypass” your water conditioner, turn valves A & B to the bypass open position (*Fig. 3.*). This will supply unconditioned water to the house.
- Check local plumbing code for approved piping. The size diameter of pipe should be equal to the size opening of the casting or larger.

- In the brine tank there is a piece of flexible brine tube. This tube runs from the brine flow control assembly (in the brine tank, *Fig. 4*) to the chlorine generator, located on the control head. Remove chlorine generator from valve and insert tubing into generator, fitting firmly; pull on tubing making sure it is secure. Do not attach other end to the brine tank, as this will be covered in start-up procedures. Reattach generator to valve, making sure clip is secure.

NOTE: Brine line should go into elbow approximately 3/4”.

- The drain line must be connected from the drain line flow control (*Fig. 4*), to a floor drain, sump pump, etc. This pipe is not provided with your water conditioner and is the responsibility of the installer. Check your local plumbing code for approved piping. In any case, it should be of adequate inside diameter to allow for proper drainage. Secure pipe to flow control and run to drain.



CAUTION: Make sure the drain, drain control and clip are attached securely to the control valve before start up.

IMPORTANT: A 2" air gap is required on the drain line.

- Notice the elbow protruding from the brine tank. It is recommended to run a line from this elbow to the drain. This is a precautionary step in case of brine tank overflow. A separate line should be run.



CAUTION: Never connect the brine tank overflow line and drain line together; however, the same drain may be used.

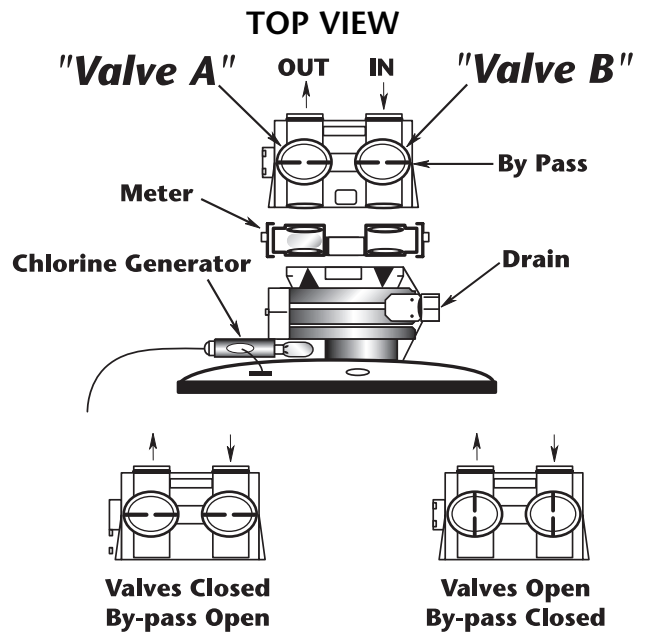

Figure 3

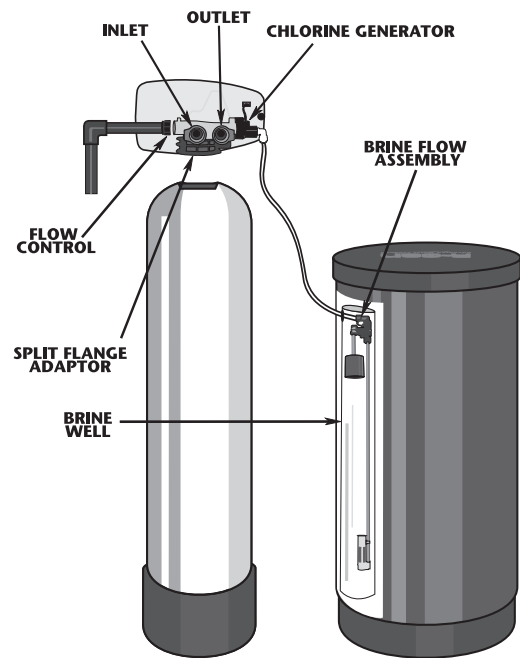

Figure 4

START-UP PROCEDURES FOR ELECTRONIC CONTROLLER:

- After installation is complete, rotate bypass handles to bypass mode (*see "Valves Closed" in Fig.3*).
- Turn on water and check for leaks.
- Fully open a cold water faucet — preferably a laundry sink or bathtub with no aerator.
- Allow water to run until clear to rid pipes of debris which may have occurred during installation.

NOTE: The system regeneration sequence for The Sanitizer Conditioner.

Backwash
Regenerate (Brine)
Rapid Rinse
Fill
Service

The system is now ready for filling with water. For the purpose of filling the softener, leave the unit in the bypass position until the 2nd step, then repeat steps 1-6 with the unit full. **Do not open the bypass at this time**, it will be filled in the backwash position. Once the unit is filled with water (step 2) then open the bypass.

1. With the softener in the bypass mode ("*Bypass valve*," *Fig. 3*) and the control valve in normal operation where the display shows either the time of day or the gallons remaining:

Manually add 5 GALLONS of water to the regenerant tank.

NOTE: If too much water is put into the brine tank during softener start up it could result in a salty water complaint after the first regeneration.

During the first regeneration the unit will draw out the initial volume of brine/regenerant and refill it with the correct preset amount.

2. Press and hold the *REGEN* button until the motor starts (3 seconds). Release button. It takes approximately 90 sec. to reach the backwash position. **See "Start an immediate extra cycle" section 4, page 10.** Once unit has reached the backwash position, unplug the transformer so that the valve does not cycle to the next position. Open the inlet handle ("*Valve B*," *Fig. 3*) of the bypass valve **very slightly** allowing water to fill the tank **slowly** in order to expel air. Once air is expelled and water is running at drain, open inlet to control.



CAUTION: If water flows too rapidly it could result in loss of media to the drain. When the water is flowing steadily to the drain without the presence of air, slowly open the inlet valve. Check that the drain can receive the flow of water. Restore power.

3. Connect brine line to brine tank. Press *REGEN* button again to put the valve into BRINE position. Display will flash No. 2 until position is reached. Check the brine line for section. Verify that water is being drawn from regenerant tank with no air leaks or bubbles in the brine line. There should be a slow flow to the drain.
4. Press *REGEN* button and place unit into rinse position. Display will flash No.3 until position is reached. Check drain line to be secure and that drain can receive the flow of water. There should be a rapid flow to the drain. Unplug transformer to keep the valve in the RINSE position. Allow to run until clear and without air. While the unit is rinsing, load the brine tank with water softener salt.

START-UP PROCEDURES FOR ELECTRONIC CONTROLLER CONT'D:



CAUTION: Damage or destruction to the media may occur if salts containing additives are used the Sanitizer models. Most "solar" and/or "block" salts do not contain additives detrimental to this unit. If unsure, please check with manufacturer. Many "pellet" or "cube" type salts are formulated with cleaning agents or additives which can cause harm to the media. Salt manufacturers do not always list additives in their products. Please check with salt manufacturers for any cleaning agents, binders or phosphate material added to salt or contact Water-Right at 920-739-9401.

NOTE: The manufacturer does recommend the brine tank be cleaned once a year to discard accumulated dirt from the salt.

5. Press the *REGEN* button and place unit into the brine tank fill position. Check to verify that the regenerant tank is filling at a rate of 1/2 gallon per minute. Check Brine line connections for leaks.
6. Press *REGEN* button again, valve will cycle back to the normal operating position with the time of day and gallons remaining displayed.
7. Repeat steps 1-6 and now check the various cycles for proper operation.
8. Once the cycle operation has been verified. Place bypass valve in the normal operating mode ("*Valves Open*," *Fig. 3*) by opening the outlet bypass handle.
9. Go to laundry tub or bathtub faucet, preferably a faucet without an aerator, and turn on the cold water, let the water run. Note the color of water coming from faucet. If discolored let water run until clear.

NOTE: At no time should there be "large particles" of media noticed at faucet or laundry tub. If this is seen immediately shut off water and bypass system as this could be an indication of a distributor failure. Contact manufacturer or distributor for assistance.

START-UP PROCEDURES FOR TIME CLOCK CONTROLLER:

- After installation is complete, rotate bypass handles to bypass mode (*see "Valves Closed" in Fig.3*).
- Turn on water and check for leaks.
- Fully open a cold water faucet — preferably a laundry sink or bathtub with no aerator.
- Allow water to run until clear to rid pipes of debris which may have occurred during installation.

NOTE: The system regeneration sequence for The Sanitizer Conditioner.

Backwash
Regenerate (Brine)
Rapid Rinse
Fill
Service

The system is now ready for filling with water. For the purpose of filling the softener, leave the unit in the bypass position until the 2nd step, then repeat steps 1-6 with the unit full. **Do not open the bypass at this time**, it will be filled in the backwash position. Once the unit is filled with water (step 2,) open the bypass.

1. Plug water conditioner into permanent electrical supply. You will hear the motor advance to the service position; this will allow the brine valve seat to seal. It is shipped open to avoid causing a premature failure.

2. With the softener in the bypass mode ("*Bypass valve,*" Fig. 3) and the control valve in normal service position (Fig. 5),
Manually add 5 GALLONS of water to the regenerant tank.

NOTE: If too much water is put into the brine tank during softener start up, it could result in a salty water complaint after the first regeneration. During the first regeneration, the unit will draw out the initial volume of brine/regenerant and refill it with the correct preset amount.

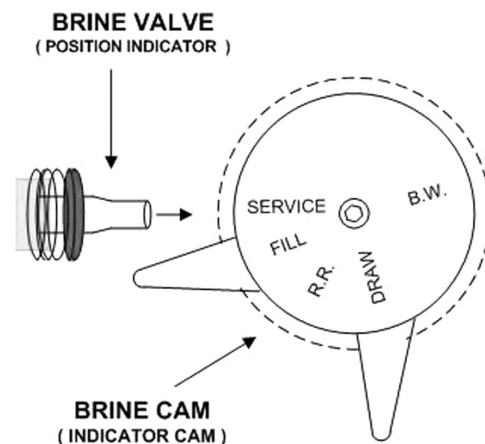

Figure 5

3. Remove cover and manually index water conditioner to the backwash cycle. To set valve in the various positions shown above, press and hold the red button in on the timer, then rotate the black center knob **very slowly** in a clockwise direction until valve drive motor starts to run. Pause and release red button. Once the motor has stopped, the control valve is in backwash position.

NOTE: Fig. 5 depicts the valve in the service position. It will take approximately 90 seconds to reach the backwash position.

4. Once unit has reached the backwash position, unplug the transformer so that the valve does not cycle to the next position. Open the inlet handle ("*Valve B,*" Fig. 3) of the bypass valve **very slightly** allowing water to fill the tank **slowly** in order to expel air. Once air is expelled and water is running at drain, open inlet to control. Let water run for 5 minutes or until clear.



CAUTION: If water flows too rapidly, it could result in loss of media to the drain. When the water is flowing steadily to the drain without the presence of air, slowly open the inlet valve. Check that the drain can receive the flow of water. Restore power.

6. Connect brine line to brine tank. Manually index control to the draw position by holding the red button in and again turning the black center knob clockwise until the drive motor starts. Once in brine position, verify that water is being drawn from regenerant tank with no air leaks or bubbles in the brine line. There should be a slow flow to the drain.

7. Manually index control to the Rapid Rinse position (RR). Check drain line to be secure and that drain can receive the flow of water. There should be a rapid flow to the drain. Unplug transformer to keep the valve in the RINSE position. Allow to run until clear and without air. While the unit is rinsing, load the brine tank with water softener salt.

8. Manually index control to the fill position again by advancing black center knob slowly. Check to verify that the regenerant tank is filling at a rate of 1/2 gallon per minute. Because the brine tank was filled in a previous step, advance control back to the service position.

9. Repeat steps 1-8 and now check the various cycles for proper operation.

10. Once the cycle operation has been verified, place bypass valve in the normal operating mode ("*Valves Open,*" Fig. 3) by opening the outlet bypass handle.

11. Go to laundry tub or bathtub faucet, preferably a faucet without an aerator, and turn on the cold water. Let the water run. Note the color of water coming from faucet. If discolored, let water run until clear.

NOTE: At no time should there be “large particles” of media noticed at faucet or laundry tub. If this is seen, immediately shut off water and bypass system as this could be an indication of a distributor failure. Contact manufacturer or distributor for assistance.

12. Proceed to programming of Time Clock Controller.

PROGRAMMING THE ELECTRONIC CONTROLLER:

When setting the Sanitizer timer, the hardness and a reserve capacity will have to be known. Below is a formula to determine the proper setting of gallons on the timer.

$$\frac{\text{Capacity of Conditioner}}{\text{Hardness}} = \frac{\text{total gallons of capacity between regenerations}}{\text{regeneration}}$$

Example: $\frac{28000^A}{25^B} = \frac{1200 \text{ gallons of capacity between regeneration}^C}{\text{regeneration}^C}$

A = Capacity of conditioner determined from capacity specification sheet. The capacity sheet is found on the back of this manual of this manual.

USE MEDIUM SALT CAPACITY.

B = Hardness

C = Total gallons usable between regeneration

Once the total gallons between regeneration has been determined, a reserve capacity must be considered. Because the controller will delay regeneration until 2:00 AM (normally), one-day supply of water must be subtracted from the total gallon capacity. To do this the daily water usage must be known. If residing in a residential area use the number of people living in the house multiplied by gallons used per person per day (assuming the average number of gallons used per day per person is 75), this will determine the daily water usage.

EXAMPLE: 3 PEOPLE IN FAMILY X 75 GALLONS = 225 RESERVE

Once the reserve capacity is known, this number must be subtracted from the total gallon capacity of the unit to determine the setting on the Sanitizer timer. *(In a commercial situation the total days usage of treated water will be used as the reserve.)*

$$\text{EXAMPLE} = 1200^C - 225^D (3 \text{ PEOPLE}) = 975^E$$

C = Total gallon usage

D = Reserve 75 gallons per person

E = Gallon setting in timer

The proper setting for the Sanitizer timer with this example would be for 975 gallons between regeneration. This gallon number would be used to set the “Treated Water Capacity” (page 10, steps 2 and 3).

SANITIZER DAYS OVERRIDE PRESET SCHEDULE:

The Sanitizer timer will automatically regenerate on a day schedule in the event the gallonage has not been reached. This has been preset by the factory.

Factory Preset Days Override:

Sanitizer ASC-1 systems 6 Days

Sanitizer ASC-2 systems 6 Days

NOTE: Under high iron conditions (5 ppm or more) the manufacturer recommends the days override be set to every 3 or 4 days.

To change the days override feature, please see “Programmable Features of the Sanitizer Timer” on page 10, step 3.

PROGRAMMING THE TIME CLOCK CONTROLLER:

1. To determine the days between regeneration, use the following formula:

$$\frac{\text{Grain Capacity of Unit}}{\text{Hardness X \# in Household X 75 gallons}} = \text{days between regeneration}$$

Example: Using an ASC2-1054

$$\frac{28000^A}{25 \text{ GPG}^B \times 4 \text{ People}^C \times 75 \text{ gallons}^D} = 3.7 \text{ days between regeneration}^E$$

- A = Capacity of unit determined from capacity spec (enclosed brochure)
- B = Hardness test result found on inside front cover
- C = Number of people in your household
- D = Amount of water used per day per person
- E = How many days between regeneration

NOTE: If days between regeneration equaled 3.7, set the unit to regenerate every 3 days. If you set to regenerate every 4 days, you may run out of soft water. If your days equaled 5, you must set the unit to regenerate every 4th day, because the timer can only be sequenced in multiples of 12. If you have any questions, please contact your installer or call Water-Right for factory assistance.

How To Set Days On Which Water Conditioner Is To Regenerate:

Rotate the skipper wheel until the number "1" is at the red pointer. Set the days that regeneration is to occur by sliding tabs on the skipper wheel outward to expose trip fingers. Each tab is one day. Finger at red pointer is tonight. Moving clockwise from the red pointer, extend or retract fingers to obtain the desired regeneration schedule (*Fig. 6*).

How To Set The Time Of Day:

Press and hold the red button in to disengage the drive gear. Turn the large gear until the actual time of day is at the time of day pointer. Release the red button to again engage the drive gear.

How To Manually Regenerate Your Water Conditioner At Any Time:

Turn the manual regeneration knob clockwise. This slight movement of the manual regeneration knob engages the program wheel and starts the regeneration program. The black center knob will make one revolution in the following approximately three hours and stop in the position shown in the drawing. Even though it takes three hours for this center knob to complete one revolution, the regeneration cycle of your unit might be set only one half of this time. In any event, conditioned water may be drawn after rinse water stops flowing from the water conditioner drain line.

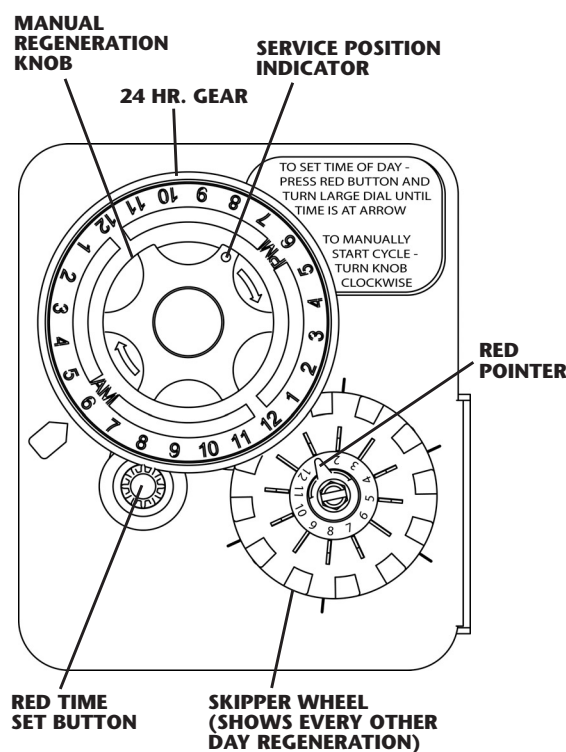
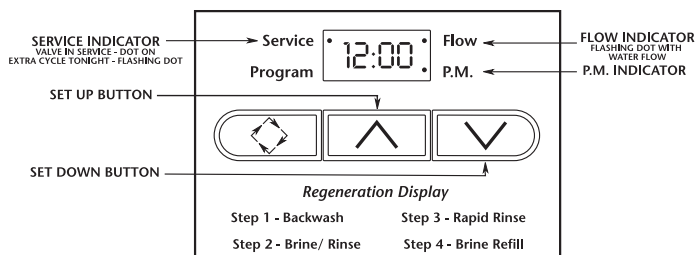

Figure 6

PROGRAMMABLE FEATURES OF THE SANITIZER TIMER:

1. Set time of day:



1. Push either the *UP* OR *DOWN* SET BUTTON once to adjust Time of Day display by one digit.
2. Push and hold either *UP* OR *DOWN* SET BUTTON to adjust Time of Day display by several digits.

2. Enter control programming mode:

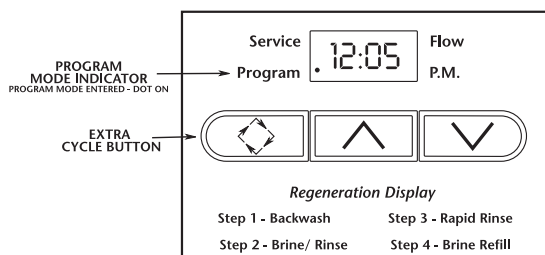

1. Push and hold both the *UP* OR *DOWN* SET BUTTON to enter programming mode.
2. Push the EXTRA CYCLE BUTTON once per display until all have been viewed and this mode is exited, normal operation can then be resumed.

3. Set control programming:

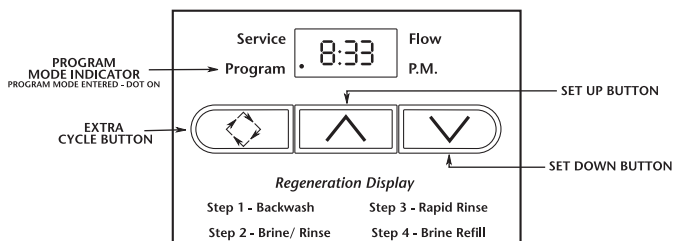

1. The first option setting display that appears in the PROGRAM MODE is TREATED WATER CAPACITY. Using the *UP* OR *DOWN* SET BUTTONS, set the amount of treated water that can flow through the unit before a regeneration is required. → FOR EXAMPLE:

Service Flow
Program P.M.
650
650 GALLONS CAPACITY

2. Push the EXTRA CYCLE BUTTON. The second option setting display that appears is REGENERATION TIME. Using *UP* OR *DOWN* SET BUTTONS, set the desired time of day when a regeneration can occur, if required.

→ FOR EXAMPLE: Service Flow
Program P.M.
2:00
2:00 A.M. REGENERATION TIME

3. Push the EXTRA CYCLE BUTTON. The third option setting display that appears is REGENERATION DAY OVERRIDE. Using *UP* OR *DOWN* SET BUTTONS, set the maximum number of days before a regeneration cycle must occur.

→ FOR EXAMPLE: Service Flow
Program P.M.
A-7
REGENERATE EVERY 7 DAYS MIN.

4. Control programming is now complete. Push the EXTRA CYCLE BUTTON. This will exit the control from the programming mode and resume normal operation.

4. Start an immediate extra cycle:

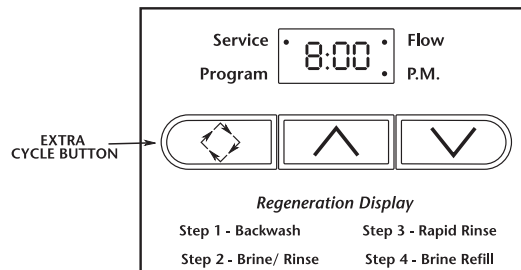

When starting an Extra Cycle you will have two options:

1. Press and Release the Extra Cycle Button:

- With IMMEDIATE REGENERATION controls the control will go into regeneration cycle immediately.
- With DELAYED REGENERATION controls the service dot will begin to flash immediately and a regeneration will occur at the preset regeneration time (ie. 2:00 a.m.).

2. Press and Hold the Extra Cycle Button for 5 seconds:

- With DELAYED REGENERATION controls this will force the control to go into regeneration cycle immediately.

5. Regeneration cycle displays:

The following series of displays appear when the control enters a regeneration cycle:

	Valve Driving To REGEN. STEP #1	service program	1--	flow P.M.
THEN	Less than 9 min. remain in REGEN. STEP #1	service program	1--8	flow P.M.
	Valve Driving To REGEN. STEP #2	service program	2--	flow P.M.
THEN	Less than 59 min. remain in REGEN. STEP #2	service program	2-58	flow P.M.
	Valve Driving To REGEN. STEP #3	service program	3--	flow P.M.
THEN	Less than 9 min. remain in REGEN. STEP #3	service program	3--8	flow P.M.
	Valve Driving To REGEN. STEP #4	service program	4--	flow P.M.
THEN	Less than 12 min. remain in REGEN. STEP #4	service program	2-11	flow P.M.
	REGEN. COMPLETE	service program	----	flow P.M.
THEN	Valve driving to service	service program	----	flow P.M.
	Valve has returned to service	service program	8:00	flow P.M.

6. Fast cycle valve through regeneration:

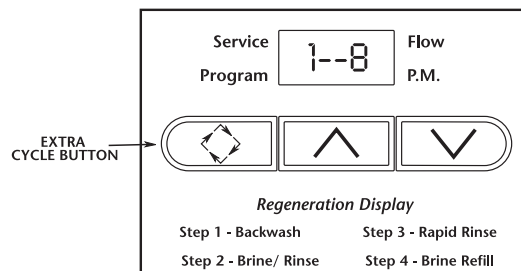

- A. Once the valve reaches REGEN STEP #1 let the water run for approximately 5 minutes to drain.

Next, manually step the valve through a regeneration cycle checking valve operation in each step:

- B. Push the EXTRA CYCLE BUTTON once to advance the valve to REGEN STEP #2.
- C. Push the EXTRA CYCLE BUTTON once to advance the valve to REGEN STEP #3 (optional).
- D. Push the EXTRA CYCLE BUTTON once to advance the valve to REGEN STEP #4 (optional).
- E. Push the EXTRA CYCLE BUTTON once more to advance the valve back to SERVICE.

LIGHT / ALARM OPERATION:

Light panel operation with audio alarm:

In the window panel of the control valve there are 3 lights, green, yellow and red.

1. The **green** light indicates the unit is in the service position delivering soft water.
2. The **red** light indicates the unit is in the regeneration cycle.
3. The **yellow** light with the **red** light indicates a failed chlorine regeneration signal and the unit is still in regeneration.
4. The **yellow** light with a **green** light indicates a failed regeneration and the unit is now in the service position. **An audio alarm will also sound every minute.** This will signal a failed chlorine regeneration.

To stop the alarm simply unplug the unit, wait 5 seconds, then plug it back in. This will clear the alarm and clear the yellow light. You will not lose any programmed information on the Sanitizer timer.

Check salt level in brine tank:

If salt level is low this will trigger the yellow light and alarm. Remember to always keep salt above water level. If salt level is good, contact dealer or refer to the troubleshooting section in this manual.

WATER CONDITIONER FLOW DIAGRAMS:

LEGEND:



ZEOLITE



GRAVEL BED



SALT

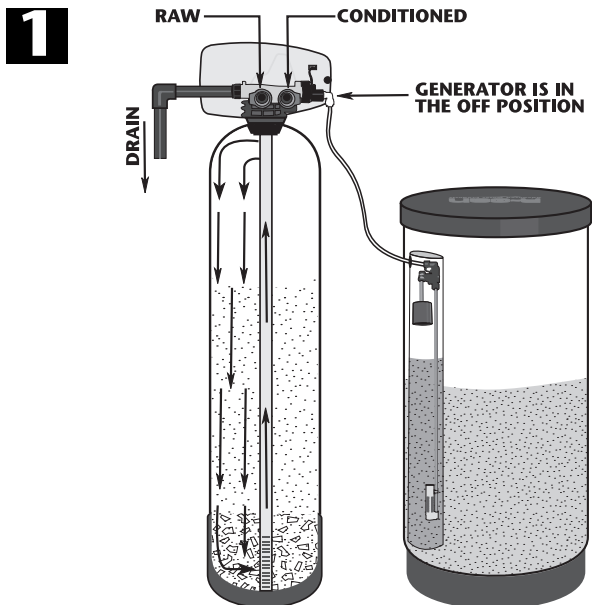

Green light is on indicating service position and that the last regeneration was proper.

1. SERVICE POSITION:

Raw water enters control head and flows down through the Zeolite mineral, removing hardness and iron (neutralizing acidic water conditions on ASC-1 models).

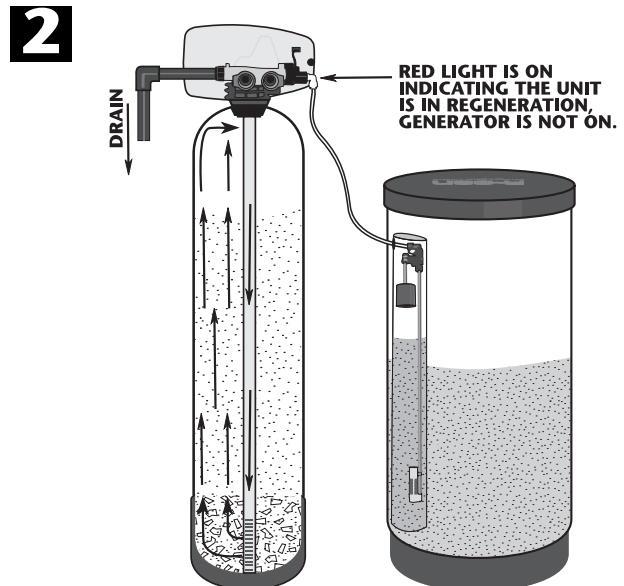

2. BACKWASH POSITION:

Raw water enters control head and flows into lower distributor upward through mineral bed and out to drain, lifting and cleaning turbid particles from Zeolite bed.

WATER CONDITIONER FLOW DIAGRAMS:

LEGEND:



3a

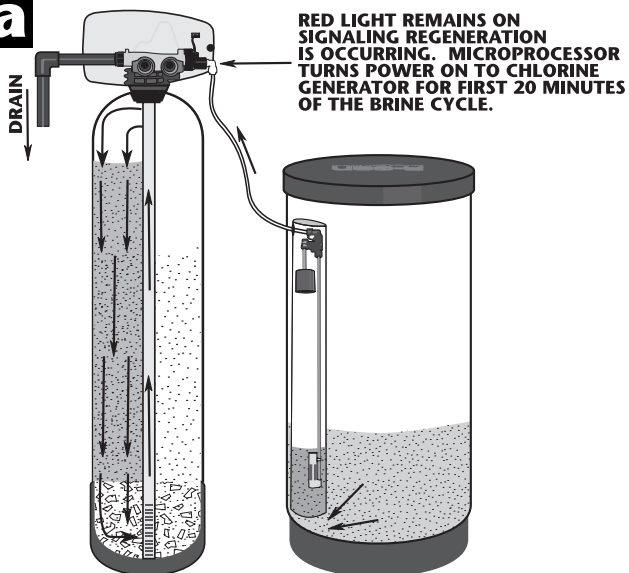

3a. BRINE RINSE POSITION:

Raw water enters control head flowing through the injector, drawing brine from the brine tank. Microprocessor turns on the chlorine generator allowing brine and chlorine to flow through the Zeolite mineral, sanitizing and regenerating the water conditioner.

3b

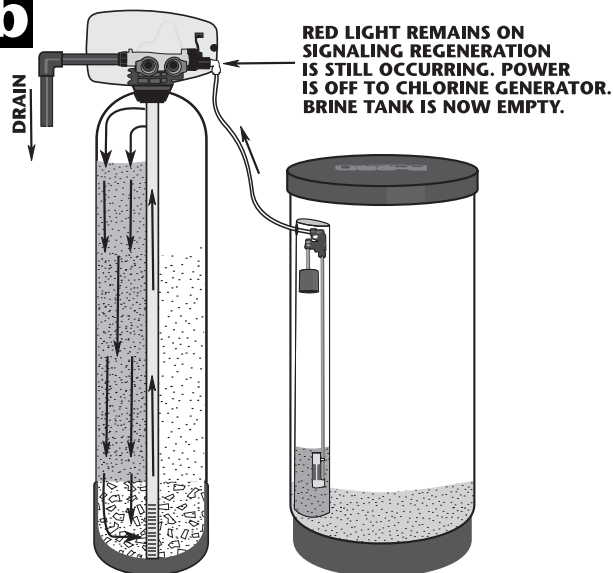

3b. SLOW RINSE POSITION:

Chlorine generator is turned off, raw water enters control head and flows down through the Zeolite mineral, rinsing chlorine and brine to drain.

4

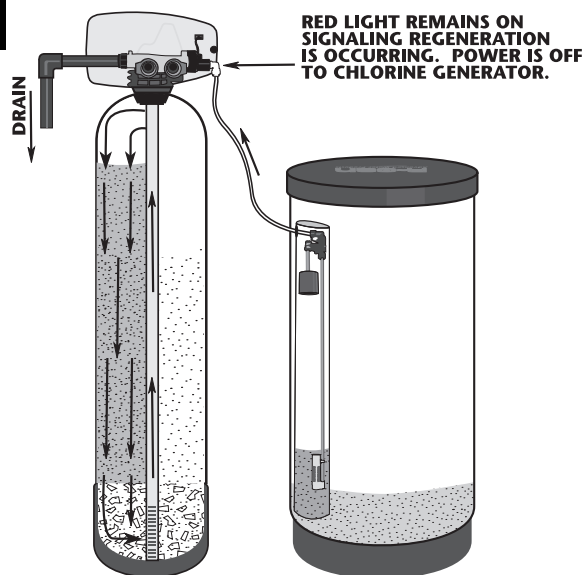

4. RAPID RINSE POSITION:

Chlorine generator is off. Raw water enters control head and flows down through the Zeolite mineral, rinsing any excess brine to drain.

5

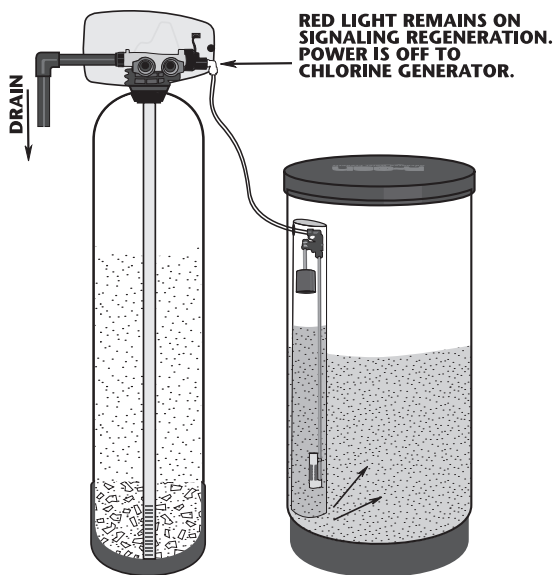

5. BRINE TANK FILL POSITION:

Water enters control head to self clean injector while flowing back to refill the brine tank. Unit will deliver soft water in this position.

TROUBLESHOOTING GUIDE:

PROBLEM	CAUSE	CORRECTION
1. Softener fails to regenerate	A. electrical service to unit has been interrupted	A. assure permanent electrical service (check fuse, plug, pull chain or switch)
	B. timer is defective	B. replace timer
	C. power failure	C. reset time of day
	D. timer programming bad	D. check programming and reset
2. Hard water	A. bypass valve is open	A. close bypass valve
	B. no salt in brine tank	B. add salt to brine tank and maintain salt level above water level
	C. injector screen plugged	C. clean injector screen
	D. insufficient water flowing into brine tank	D. check brine tank fill time and clean brine line flow control if plugged
	E. hot water tank hardness	E. repeated flushing of the hot water tank as required
	F. leak at distributor tube	F. make sure distributor tube is not cracked, check O-ring and tube pilot
	G. internal valve leak	G. replace seals and spacers and/or piston
	H. flow meter jammed	H. remove obstruction from meter
	I. flow meter cable disconnected	I. check meter cable connection to timer and meter
	J. improper programming	J. reprogram the control for proper regeneration type, inlet hardness, capacity or flowmeter size
3. Unit used too much salt	A. improper salt setting	A. check salt usage and salt setting
	B. excessive water in brine tank	B. see problem no. 7
	C. improper programming	C. check programming, reset
4. Loss of water pressure	A. iron buildup in line to water conditioner	A. clean line to water conditioner
	B. iron buildup in water conditioner	B. clean control head and increase frequency of regeneration
	C. inlet of control plugged due to foreign material broken loose from pipes	C. remove piston and clean control head
5. Loss of mineral through drain line	A. air in water system	A. assure that well system has proper air eliminator control -- check for dry well condition
	B. drain line flow control too large	B. check flow control -- change if needed

PROBLEM	CAUSE	CORRECTION
6. Iron in conditioned water	A. fouled mineral bed	A. check backwash, brine draw and brine tank fill -- increase frequency of regeneration
7. Excessive water in brine tank	A. plugged drain line flow control	A. clean flow control
	B. brine valve failure	B. replace brine valve
	C. improper programming	C. check program -- reset
	D. faulty air check or safety float	D. replace complete safety float assembly
8. Salty water in service lines	A. plugged drain line flow control	A. clean flow control
	B. plugged injector system	B. clean injector and screen
	C. timer not cycling	C. replace timer
	D. foreign material in brine valve	D. replace brine valve seat and clean valve
	E. foreign material in brine line flow control	E. clean brine line flow control
	F. low water pressure	F. raise water pressure
9. Softener fails to draw brine — Yellow Light Indication	A. drain line flow control is plugged	A. clean drain line flow control
	B. injector is plugged	B. clean injector and port behind injector
	C. injector screen plugged	C. clean screen
	D. line pressure is too low	D. increase line pressure to 25 psi
	E. internal control leak	E. change seals, spacers and piston assembly
	F. improper programming	F. check programming -- reset
	G. probes scaled in chlorine generator	G. clean or replace chlorine generator
	H. drawing air during regeneration	H. check brine line connections
	I. electrical malfunction	I. replace board or wire harness
10. Control cycles continuously	A. broken or shorted micro-switch	A. determine if switch or timer is faulty and replace
	B. faulty cam operation	B. replace or reinstall cam
11. Drain flows continuously	A. valve not programming correctly	A. check time program and positioning of control
	B. foreign material in control head	B. remove power head assembly and inspect bore, remove foreign material and check control in various regeneration positions
	C. internal control leak	C. replace seals and piston assembly
	D. drive motor jammed in regeneration	D. replace seals and piston, drive motor, check for broken gears

REPLACEMENT PARTS:

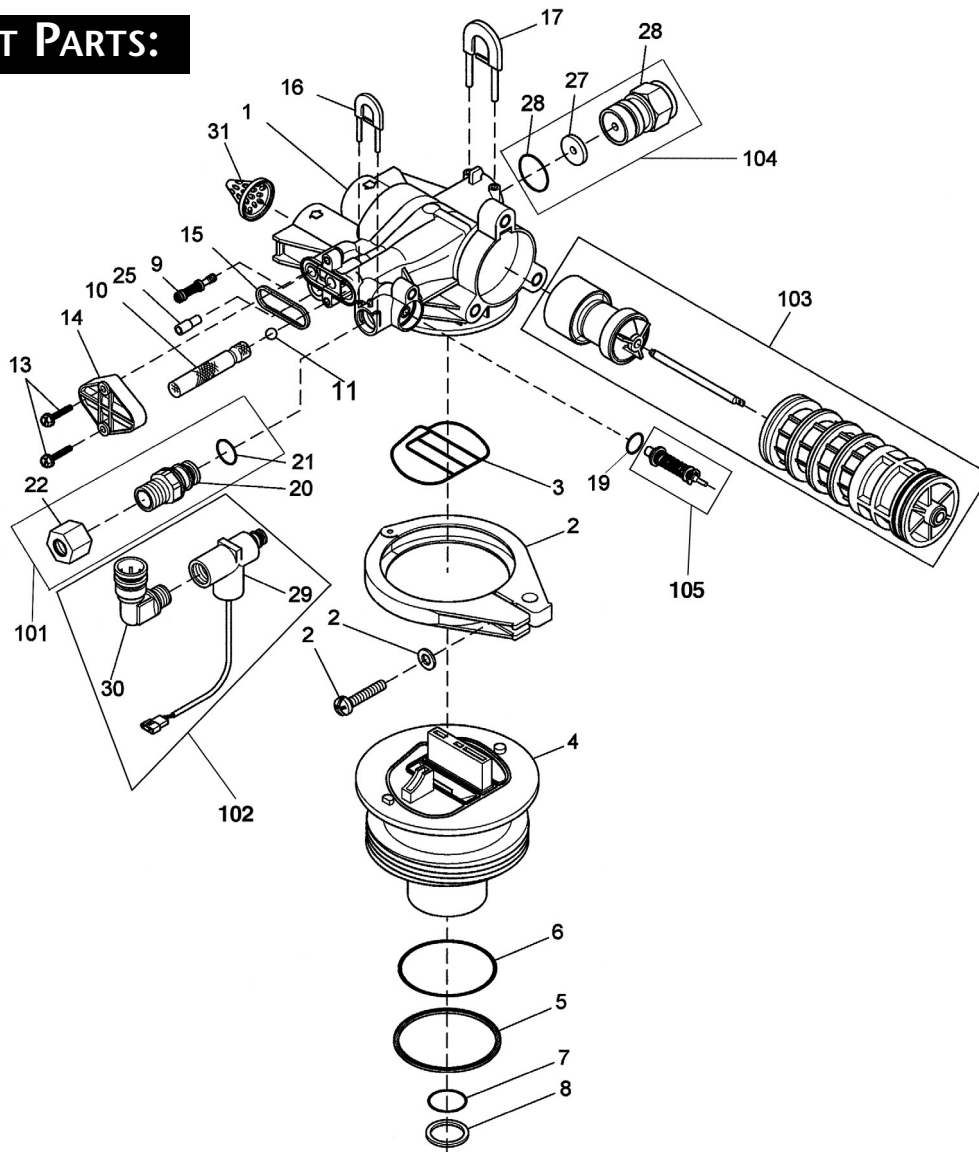

CONTROL VALVE ASSEMBLY

Item No.	Part No.	Description	Item No.	Part No.	Description
1	FP19350-05	4200 valve body 1"	23	FP13287	Ring & seal cartridge o-ring (not shown)
2	FP60503	4200 clamp assembly	24	FP18273	Vortex generator (not shown)
3	FP19914	4200 base seal	25	FP18276-01	Injector plug assembly
4	FP19344-05	4200 valve base	27	FP12085	1.2 GPM DLFC button
5	FP19197	Valve base slip ring		FP12086	1.5 GPM DLFC button
6	FP18303	O-ring top of tank		FP12088	2.4 GPM DLFC button
7	FP13304	Dist. tube o-ring		FP12089	3.0 GPM DLFC button
8	FP13030	Dist. tube o-ring retainer		FP12089	3.0 GPM DLFC button
9	FP18272-0	4200 injector #0 red (no longer used)		FP12090	3.5 GPM DLFC button
	FP18272-1	4200 injector #1 white		FP12091	4.0 GPM DLFC button
	FP18272-2	4200 injector #2 blue		FP12092	5.0 GPM DLFC button
10	FP40246	4200 injector screen		FP12408	7.0 GPM DLFC button
11	FP11482	3/16" injector ball		FP12087	2.0 GPM DLFC button
13	FP18262	4200 injector cover screw		FP17814	6.0 GPM DLFC button
14	FP18277	4200 injector cover	28	FP60705-00	Plastic DLFC
15	FP18301	Injector capseal o-ring	29	WR00030	Chlorine generator
16	FP19484	BLFC retainer clip	30	JG-L38T38S	John Guest elbow for generator
17	FP18312	DLFC retainer clip	31	FP14613	Flow straightener
18	FP13287	4200 ring & seal base o-ring (not shown)	ASSEMBLY		
19	FP13302	Brine valve o-ring	101	WR00160A	Brine valve fitting with nut & ferruls
20	FP19335	4200 brine valve fitting	102	WR00030A	Chlorine generator assembly
21	FP13302	Brine valve fitting o-ring	103	FP60159-01	Piston/ring & seal cartridge assembly
22	FP19625	Brine valve fitting nut assembly	104	FP60705-00	Plastic DLFC
			105	FP60032-002	Brine valve assembly

REPLACEMENT PARTS:

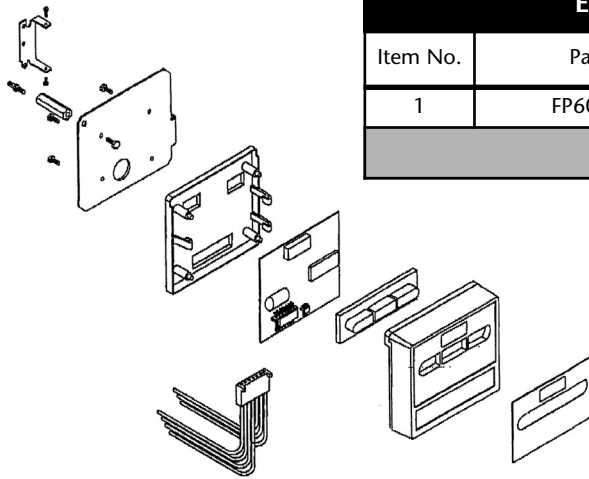

ELECTRONIC TIMER ASSEMBLY		
Item No.	Part No.	Description
1	FP60314-02	3200 simplified electronic timer complete
Individual parts not available.		

ELECTRONIC TIMER ASSEMBLY		
Item No.	Part No.	Description
1	WR00040	Dual voltage 4 wire transformer
	19674	Single voltage 2 wire transformer
2	FP19970	Valve backplate
3	FP19971	Valve cover
	FP19973	Cover door
	FP19972	Cover window
4	WR00050	Flanged style u-nut for cover (not shown)
5	WR00060	U-style tapped hole nut (not shown)
6	WR00070	#10 washer for cover door (not shown)
7	WR00080	Cover screw with knurled head
10	FP17020	Timer mounting screw 4200
12	FP40050	4200 motor mount screw
13	FP13296	4200 idler gear screw
14	FP13547	Cord strain relief
15	FP19577-01	4200 brine cam
16	FP13314	4200 brine cam screw
17	FP19619	Idler bracket
18	FP19598	Idler gear
19	FP10339	#4-40 nut for micro-switch
20	FP19581	Motor bracket
21	FP19523	Drive cam
22	FP15137	Upper #10-24 brine screw
23	FP10231	1/4-20 backplate screw
24	FP10218	Drive micro-switch
25	FP19111	Micro-switch mounting screw
26	FP13363	Piston arm washer
27	FP11335	#4-40 piston arm screw
28	FP19688	Piston rod link
29	FP40055-05	Brine valved bracket
30	FP19493	Drive shaft
31	FP19597	24 volt drive motor
32	FP12681	Wire nut
33	FP15137	Brine bracket screw
34	WR00020	Chlorinator circuit board
35	FP17967	Meter cable strain relief
36	FP60314-02	Timer assembly
37	FP40154	Chlorinator wire harness
38	WR00100	#4 washer for circuit board
39	WR00110	18-8 SS screw for circuit board
	FP60162-41	4200 drive assembly (not shown)
ASSEMBLY		
	FP19971A	Sanitizer cover assembly

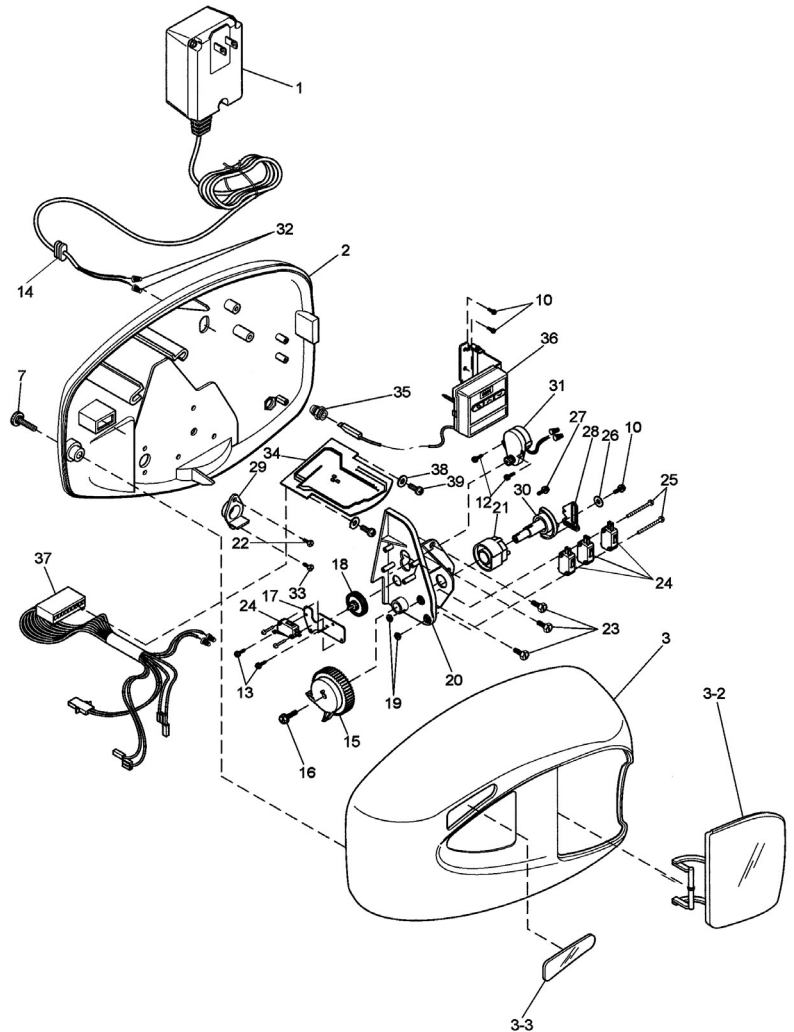

REPLACEMENT PARTS:

PLASTIC BYPASS ASSEMBLY

Item No.	Part No.	Description
1	FP19723	Bypass valve body, plastic
2	FP11183	O-ring, .015
4	FP17512	Screw, hex washer head, #6-24x3
9	FP9452K83	O-ring - 119
10	FP13255	Mounting clip
11	FP13314	Screw, hex washer head 8-18x5/8
12A	FP18706	Yoke, plastic 1" NPT
12B	FP13708	Yoke, 3/4" brass
	FP13708-40	Yoke, 1" sweat
	FP13708-45	Yoke, 3/4" sweat
	FP18706-02	Yoke, 3/4" NPT plastic
	FP41027-01	Yoke, stainless 3/4" NPT
	FP41026-01	Yoke, stainless 1" NPT
	FP19620-01	Yoke assm, 3/4", right angle, 90
	FP40636	Yoke, 1-1/4" NPT brass
ASSEMBLY		
	FP60049	Plastic bypass assembly

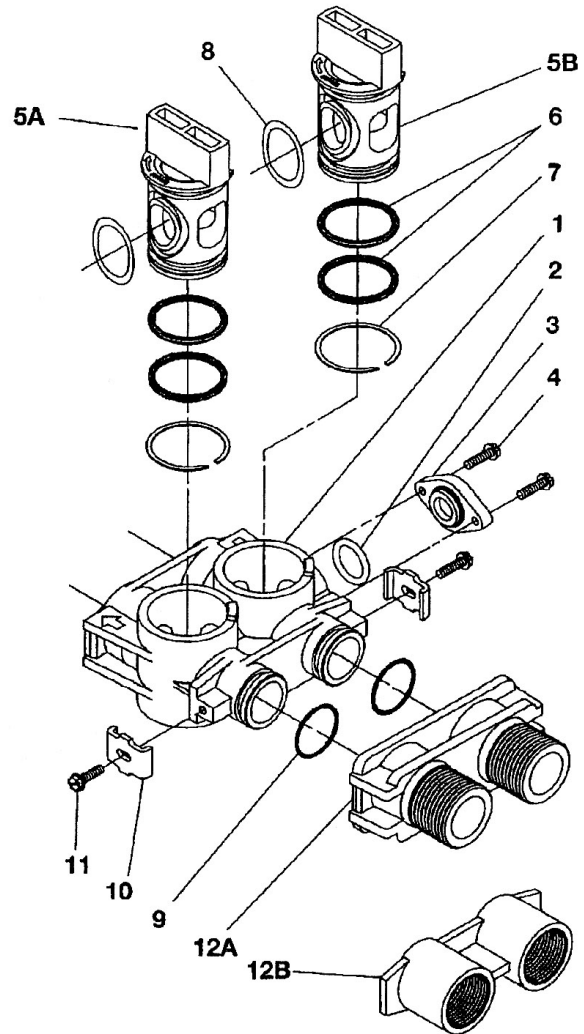

REPLACEMENT PARTS:

ELECTRONIC METER ASSEMBLY

Item No.	Part No.	Description
1	FP13314	Screw, hex washer, 8-18 x 5/8"
2	FP19569	Flow meter clip
3	FP19797	Meter body assembly, 3/4" turbin
4	FP9452K83	O-ring meter body
5	FP19791-01	Flow meter harness assembly

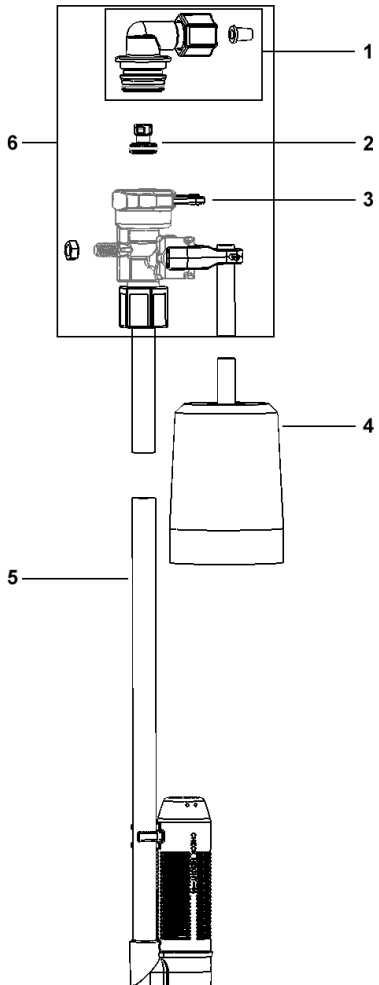
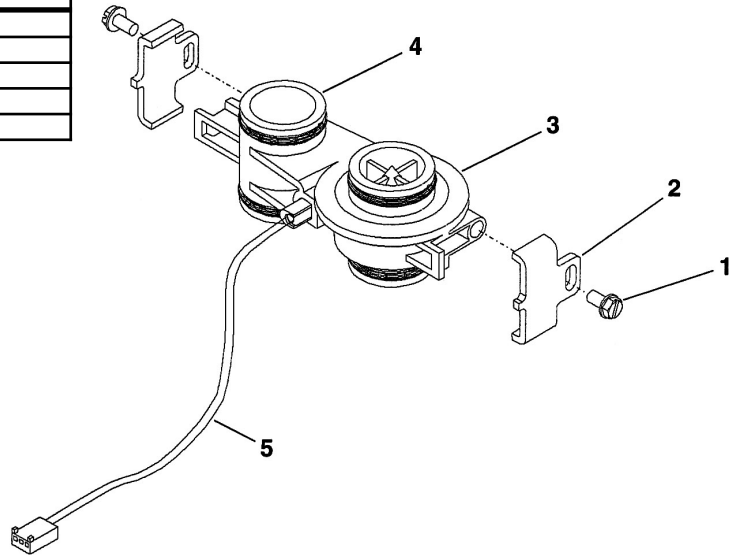

SAFETY FLOAT ASSEMBLY

Item No.	Part No.	Description
1	CH4650-01	474 safety elbow 3/8"
2	CH4655	474 .5 gpm flow control
3	CH4615	Elbow locking clip
4	CH4640-32	474 float assm 32" w/ grommets
5	CH4500-48	474 aircheck assm 1/2" x 48"
6	CH4600	474 safety brn vlv w/ 3/8" elbow
7	CH4600-50	474 safety brn vlv .5 GPM
100	CH4700-27WR-1	.5 gpm safety float a/c assm com

BLANK

CAPACITY & PHYSICAL SPECIFICATIONS:

CAPACITY SPECIFICATIONS

MODEL	ASC1-1044T		ASC1-1054T		ASC1-1354T		ASC2-1044T		ASC2-1054T		ASC2-1354T	
	ASC1-1044ME		ASC1-1054ME		ASC1-1354ME		ASC2-1044ME		ASC2-1054ME		ASC2-1354ME	
Capacity: (Grains/lbs. NACL)	Maximum	11,800 @ 12.4	22,600 @ 15.9	36,900 @ 21.2	20,300 @ 12.4	34,800 @ 15.9	60,300 @ 26.5					
	Medium	11,400 @ 9.3	20,700 @ 12.4	33,600 @ 15.9	19,100 @ 9.3	32,000 @ 12.4	48,300 @ 15.9					
	Minimum	7,300 @ 3.2	16,400 @ 6.1	28,300 @ 9.5	11,100 @ 3.2	22,900 @ 6.1	28,200 @ 9.3					
Efficiency (gr./lb) @ lowest setting	2,300	2,700	3,100	3,500	3,800	3,000						
Amount of Media	1.0	1.5	2.5	1.0	1.5	2.5						
Maximum Water Hardness (gpg)	20	30	40	40	60	80						
Maximum Iron/Manganese (ppm)	8.0	10.0	15.0	8.0	10.0	15.0						
Minimum pH Required	6.5	6.0	6.0	7	7	7						
Peak Flow Rate (gpm @ p-psi)	19 @ 15.0	17 @ 15.0	19 @ 15.0	19 @ 15.0	17 @ 15.0	19 @ 15.0						
Continuous Flow Rate (gpm @ p-psi)	9.0 @ 5.0	8.0 @ 5.0	9.0 @ 5.0	9.0 @ 5.0	8.0 @ 5.0	9.0 @ 5.0						
Water Pressure Range (psi)	25-100	25-100	25-100	25-100	25-100	25-100						
Water Temp °C (°F)	33-100°F	33-100°F	33-100°F	33-100°F	33-100°F	33-100°F						
Electrical Requirements (volts-hertz)	110-50/60	110-50/60	110-50/60	110-50/60	110-50/60	110-50/60						
Pipe Size	1"	1"	1"	1"	1"	1"						
Total Dimension: (overall)	Media Tank (width x height)	10" x 52"	10" x 62"	13" x 62"	10" x 52"	10" x 62"	13" x 62"					
	Brine Tank (width x height)	18" x 33"	18" x 33"	18" x 40"	18" x 33"	18" x 33"	18" x 40"					
Shipping Weight(lbs)	95 lbs	120 lbs	180 lbs	95 lbs	120 lbs	180 lbs						

SULPHUR REDUCTION — For applications requiring the additional removal of Hydrogen Sulphide up to .5 ppm (sulphur or "rotten egg" smell), special systems are available which include KDF media between the gravel underbed and the Crystal-Right® zeolite.

- All Sanitizer Series Water Conditioners are prefactory set at medium salting. Note: influent waters must be at least 3 gpg and have a TDS of 80 ppm. A calcite or corsex unit may be needed for correct operation.
- Iron removal may vary depending on form of iron, pH and other local conditions. On waters that are prechlorinated or where other preoxidation occurs, an iron precipitate can form that is too small to be filtered.
- The pH listed is the minimum for the influent water.
- This is the minimum number of gallons at the continuous flow rate corrected to a 7 pH. The actual amount of pH adjusted water may be greater.
- Unit not tested for capacity at these flow rates. Water quality may vary.

PHYSICAL SPECIFICATIONS

Model Number	Media Tank			Brine Tank		Top View		Distance to Media Freeboard (approx.)	Salt Storage	Amount of Media	Total Weight
	Diameter	Height	Total Height	Diameter	Height	Top of Conditioner	Brine Tank				
	A	B	C	D	E	F	G				
1044	10"	44"	52"	18"	33"	14"	18"	13"	300 lbs.	1.0 cu. ft.	95 lbs.
1054	10"	54"	62"	18"	33"	14"	18"	16"	300 lbs.	1.5 cu. ft.	120 lbs.
1354	13"	54"	62"	18"	40"	14"	18"	16"	400 lbs.	2.5 cu. ft.	180 lbs.

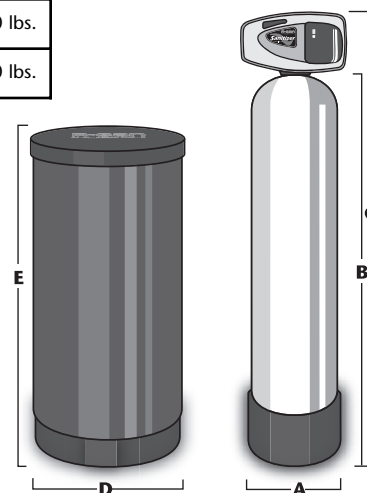
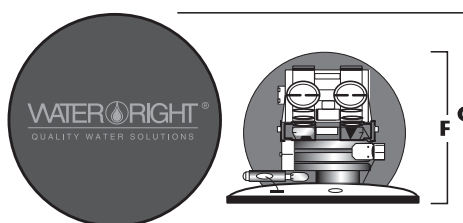

WATER RIGHT®
QUALITY WATER SOLUTIONS

1900 Prospect Court • Appleton, WI 54914
Phone: 920-739-9401 • Fax: 920-739-9406